



# ECCG VMEbus Blades Overview

Rob Persons

# MVME5100

## - Feature Overview

- **CPU**

- PowerPC 7400 @ 400 MHz, 2 MB External L2 cache
- PowerPC 750 @ 450 MHz, 1 MB External L2 cache
- 100 MHz FSB (Front Side Bus)

- **System Controller**

- ECCG “Hawk” ASIC

- **Memory**

- 64 or 512 MB on-board PC100 ECC memory
- Up to 512 MB additional memory using RAM 500 expansion modules

- **I/O**

- Dual PMC Slots: PCI A32/D32/D64 @ 33 MHz
- One 16550 serial port (RJ-45 on front panel)
- Two 10/100 Ethernet ports (RJ-45s on front panel)
- Other I/O provided by MVME761 transition module & IPMC761 Rear I/O PMC Module
- VME64 Interface (Universe II Chip)

# MVME5100

## - Block Diagram

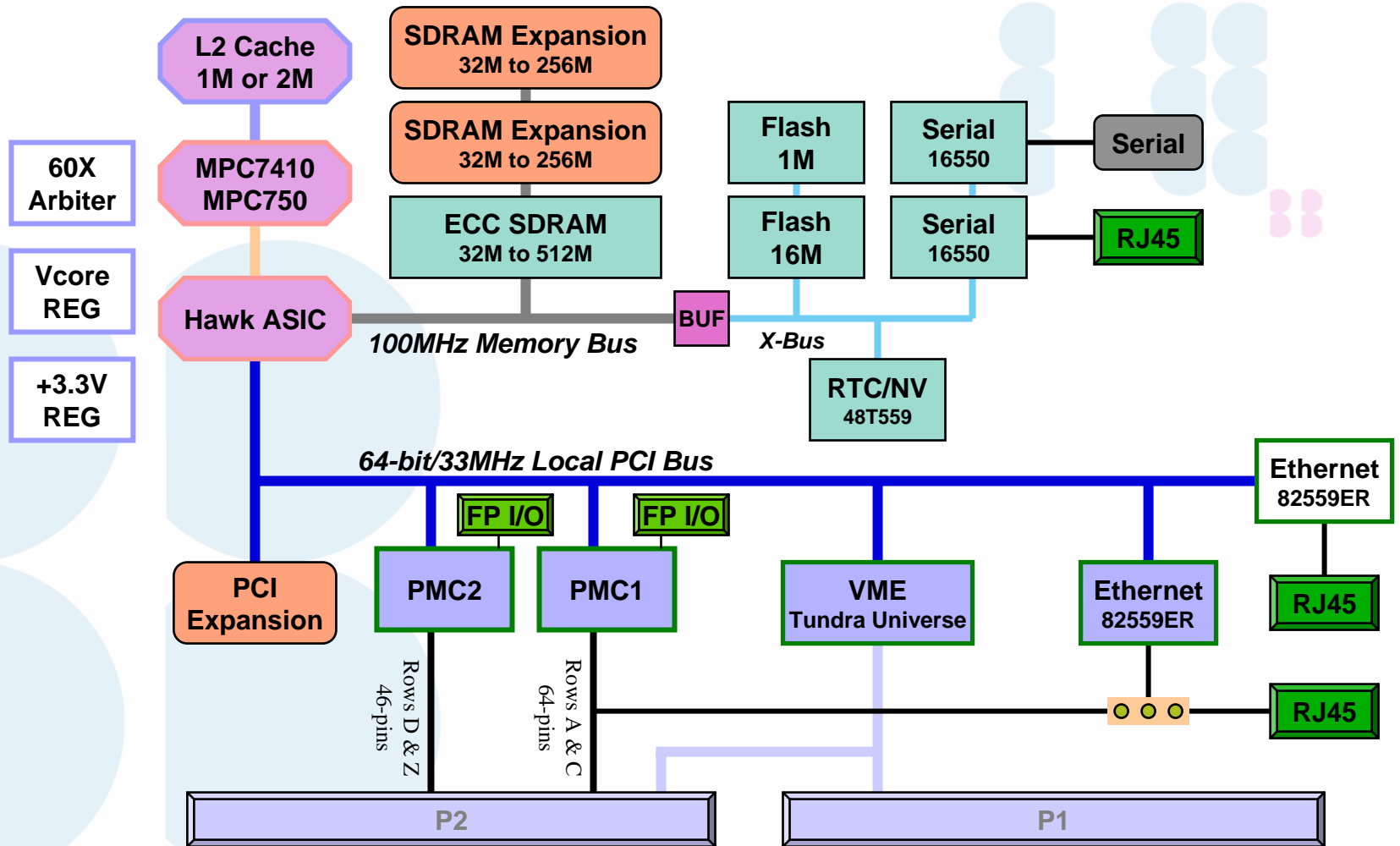

# MVME5100

## - Software/Support

- **Firmware**
  - PPC Bug
- **Operating Systems**
  - VxWorks 5.5.1
  - TimeSys Linux 2.4
  - LynxOS
  - Green Hills Integrity
- **I/O Module Support**
  - IPMC761 (Rear I/O PMC Module)
  - MVME761 (Rear Transition Module)
  - PMCSpan
- **Power Consumption**
  - 19.6 W typical



# MVME5500

## - Feature Overview

- **CPU**

- MPC7455 @ 1 GHz, 256K L2 cache on-chip
- 2 MB External L3 Cache

- **System Controller**

- Marvell Discovery I

- **Memory**

- 512 MB of on-board PC133 ECC Memory
- Optional 512 MB Mezzanine for additional memory (precludes PMC1)

- **I/O**

- Dual PMC Slots: PCI A32/D32/D64 @ 33/66 MHz
- One 16550 serial port (RJ-45 on front panel)
- One 10/100 Ethernet port & one 10/100/1000 Ethernet port (front)
- Other I/O provided by MVME712M/761 transition modules & IPMC712/761 Rear I/O PMC modules
- VME64 Interface (Universe II Chip)



# MVME5500

## - Block Diagram

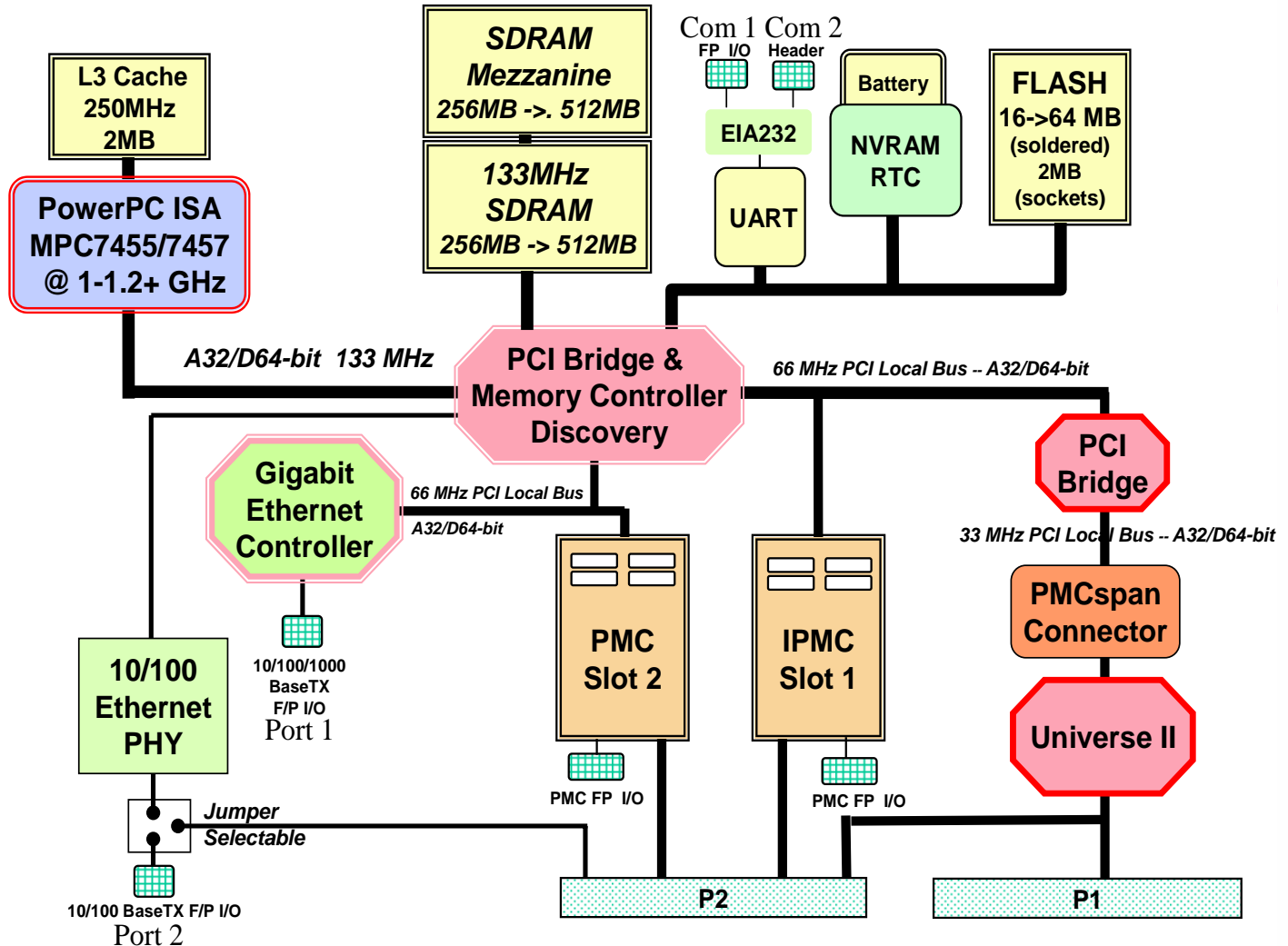

# MVME5500

## - Software/Support

- **Firmware**
  - MotLoad
- **Operating Systems**
  - VxWorks 5.5.1
  - TimeSys Linux 2.4 (moving to 2.6 in the future)
  - LynxOS
  - Green Hills Integrity
- **RTM Support**
  - IPMC712/761 (Rear I/O PMC Modules)
  - MVME712M/761 (Rear Transition Modules)
  - PMCSpan
- **Power Consumption**
  - 33.5 W typical



# MVME6100

## - Feature Overview

- **CPU**

- MPC7457 @ 1.267 GHz, 512K L2 cache on-chip
- 2 MB External L3 Cache

- **System Controller**

- Marvell Discovery II

- **Memory**

- 512 MB or 1 GB of on-board DDR266 ECC Memory

- **I/O**

- Dual PMC-X Slots: PCI-X A32/D32/D64 @ 33/66/100 MHz
- One 16550 serial port (RJ-45 on front panel)
- Two 10/100/1000 Ethernet ports (RJ-45 on front panel)
- Other I/O provided by MVME712M/761 transition modules & IPMC712/761 Rear I/O PMC modules
- 2eSST VME Interface (Tundra TSi148)



# MVME6100

## - Block Diagram

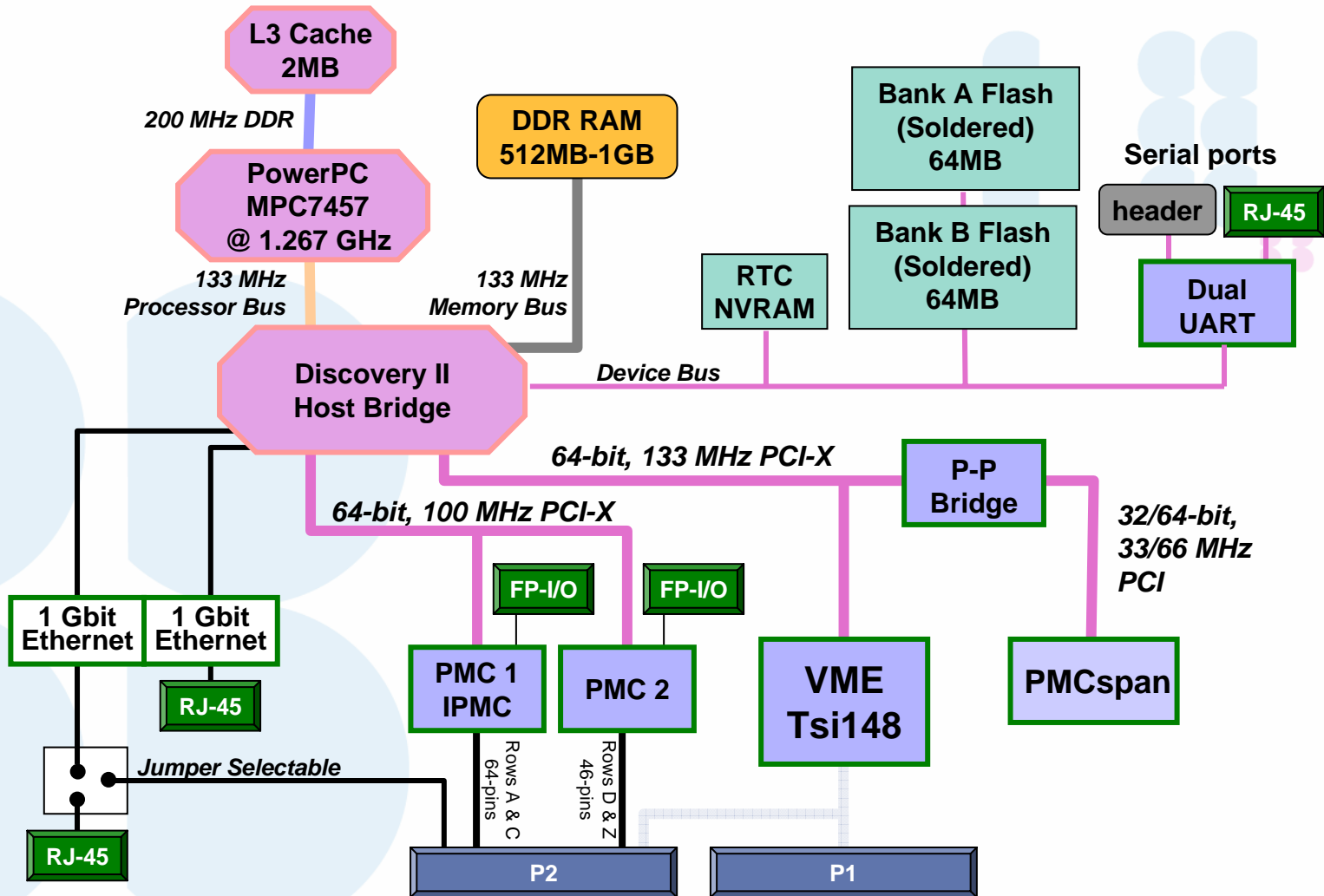

# MVME6100

## - Software/Support

- **Firmware**
  - MotLoad
- **Operating Systems**
  - VxWorks 5.4.2, 5.5, 5.5.1
  - TimeSys Linux 2.6
  - LynxOS (planned)
- **RTM Support**
  - IPMC712/761 (Rear I/O PMC Modules)
  - MVME712M/761 (Rear Transition Modules)
  - PMCSpan
- **Power Consumption**
  - 42 W typical



# MVME3100

## - Feature Overview

- **CPU**
  - MPC8540 (PowerQUICC III) @ 833 MHz, 256K L2 cache on-chip
- **System Controller**
  - Integrated with CPU
- **Memory**
  - One SODIMM Socket
  - Supports up to 1 GB of DDR333 ECC Memory (DDR II Technology)
- **I/O**
  - Dual PMC-X Slots: PCI-X A32/D32/D64 @ 66/100 MHz
  - Front Panel: 1 Serial Port, 1 GbE Port, 1 USB 2.0 Port & 1 SATA
  - Rear I/O: 4 Serial Ports, 1 GbE Port, 1-10/100 Ethernet Port, 1 USB 2.0 Port, & 1 SATA Port
  - Rear I/O brought out to MVME3100 RTM Board
  - 2eSST VME Interface (Tundra TSi148)

# MVME3100

## - Block Diagram

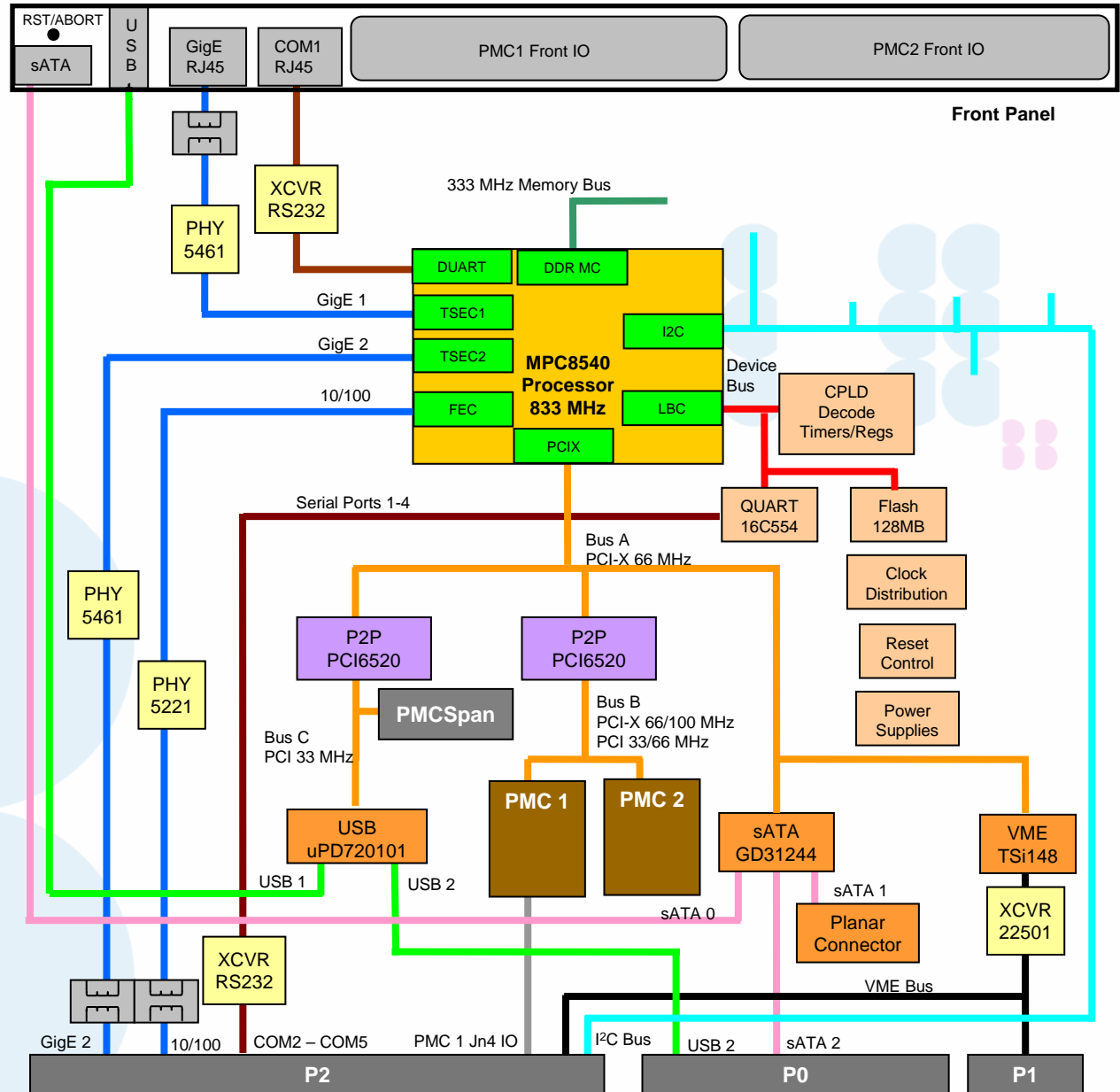



# MVME3100

## - Software/Support

- **Firmware**
  - MotLoad
- **Operating Systems**
  - VxWorks 5.5.1, 6.0
  - TimeSys Linux 2.6
  - LynxOS (planned)
- **RTM Support**
  - MVME3100 RTM
- **Power Consumption**
  - 39.5 W typical

